

# BDSS

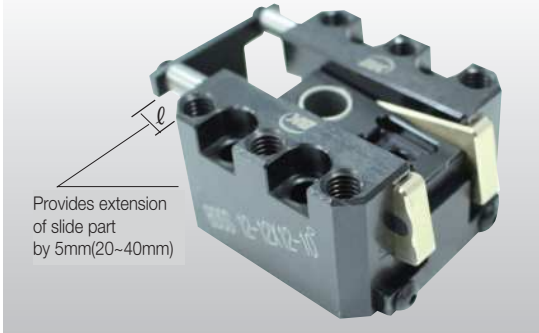

■ Non-lubricant Universal Slide Core Unit - Advantage

- This slide unit leads the angular pin to slide in smooth way when core moves inclined injection including any undercut.
- This slide unit adjusts by itself center, therefore it prevents wear and stick of the guide and the slide plate.

No	Description	Q'ty	Material
1	Slide Block	2	SCM440
2	Core shaft Block	1	SCM440
3	Bushing	1	DU
4	Guide Plate	2	#500SP(CAC304+Gr)
5	Stopper Plate	2	SS41

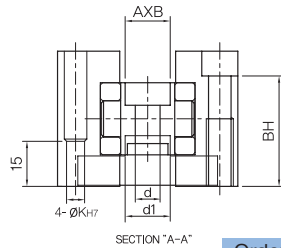
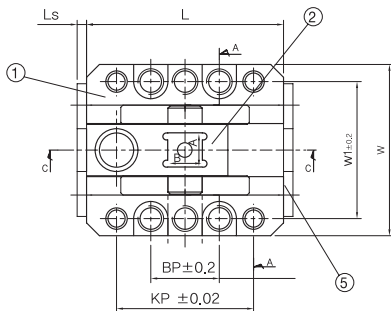

Order → Catalog Code **A × B - θ°**  
BDSS - 10 × 12 - 5°

\*Take off ⑤ Stopper Plate when assemble on injection tool.

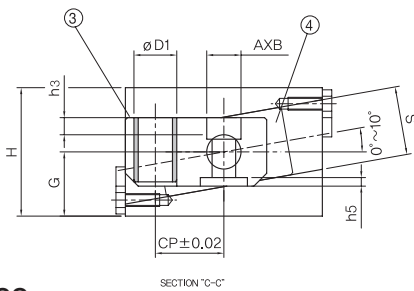

∅ D	h2	C1	Ls	Ⓐ	Ⓑ	Over10.1° (θ)
6	-	3	4.8	0° ~ 10°	0°	H+10
8	-	3	4.8	0° ~ 10°	-	Quotation by drawing
10	-	4	4.8	0° ~ 10°	-	
12	3	5	4.8	0° ~ 10°	-	
16	5.5	6	4.8	0° ~ 10°	-	
20	5.5	6	4.8	0° ~ 10°	-	
25	3.5	6	4.8	0° ~ 10°	-	

**BDSS**

A×B	D1	W	L	H	W1	BP	KP	CP	h3	ℓ	S	B	BH	BM	∅ K	d1	∅ d
8×8	6	38	46	30	30	16	32	15	4	30	16	M4	23.5	M6	4	-	4.5
10×10	8	40	46	30	32	16	32	20	4	30	16	M4	23.5	M6	4	-	5.5
12×12	10	56	55	35	45	21	42	20	4	35	20	M6	27.5	M8	6	-	5.5
16×16	12	60	65	36	48	25	46	25	5	40	20	M6	28.5	M8	6	16	9
20×20	16	68	70	43	55	25	50	30	5	40	24	M8	33.5	M10	8	20	11
25×25	20	75	80	45	62	35	60	35	6	45	26	M8	35.5	M10	8	20	11
30×30	25	81	95	54	68	50	75	40	6	55	30	M8	43.5	M10	8	20	11