

BGB

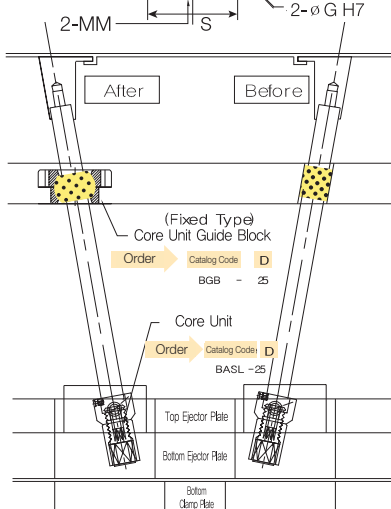

Patent No. : 10-0592347

No.	Description	Q'ty	Material
1	Guide Block	2	SCM-4
2	Guide Holder	1	#500SP(CAC304+Gr)
2	Guide Holder	1	SKD61 HFC 58

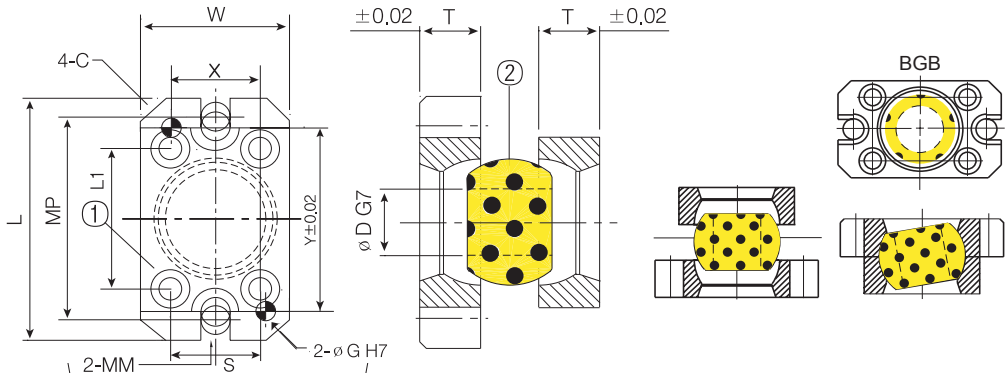

Catlog Nb.	D	L	W	T	MM	MP	stroke	X	Y	S	L1	C	G
BGB	6,8	48	30	9,5	M5	38	2	14	36	18	24	5	4
	10	50	32	11		40	2	16	38	20	26	5	
	12	58	34	12	M6	46	2	18	44	20	28	5	6
	16	70	40	15		56	2	22	52	24	36	6	
	20	76	46	18	M8	62	2	26	62	28	44	6	8
	25	86	52	20		70	2	30	70	34	50	8	
	30	92	58	23	M10	76	2	36	76	38	58	8	8
	35	108	72	26		88	2	46	88	48	64	10	
	40	114	78	29	M12	94	2	52	94	54	70	10	

Before

Each guide bushings in the guide blocks are supporting the each point.

After

BGA guide blocks are adjust by themselves the small difference caused by the processing and design failure, therefore It gets rid of the risk of scratch.

Order → Catalog Code **D** **SKD61**
 BGB - 25
 BGB - 25 - D