

# BNPL



특허청  
COMMISSIONER, THE KOREAN INTELLECTUAL PROPERTY COMMISSION



Patent No. : 10-0887386



\* Assembling Manual - page 66~67

No.	Description	Q'ty	Material
1	Core shaft Block	1	SCM440
2	Guide Plate	2	#500SP(CAC304+Gr)
2	Guide Plate	2	SKD61 HRC 58
3	Key	1	S45C
4	Control Bolt	1	SCM400
5	Fasten Nut	1	SCM400

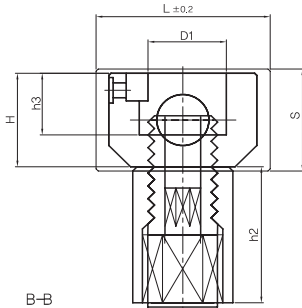
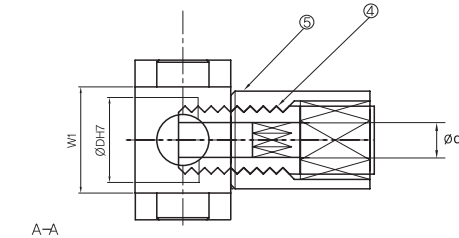
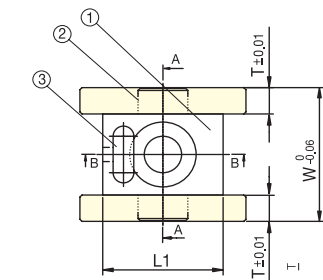

Order → Catalog Code **D** SKD 61

BNPL - 25  
BNPL - 25 - D  
Assembling Tod BCL-25

■ Fitting (Description)

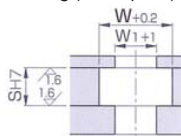

■ Guide Shaft BGPA BGPM

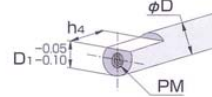

ø D	W	W1	T	L	L1	S		H	h2	h3	D1	ø d	PM
12	30	17	6.5	35	25	20	-0,01	16	20	11,5	11	5,2	M5
16	33	20	6.5	40	29	20		18	22	12,5	15	8,2	M8
20	38	25	6.5	40	34	24		22	25	14,5	18	10,5	M10
25	45	31	7	45	38	26	-0,03	26	28	16,5	22	12,5	M12
30	51	36	7,5	55	43	30		30	30	18,5	27,5	12,5	M12
35	60	42	9	70	48	34		36	30	21,5	32,5	16,5	M16
40	67	47	10	80	53	38		40	30	23,5	37,5	16,5	M16