

BDNL



Patent No. : 10-0802150



No	Description	Q'ty	Material
1	Core shaft Block	1	SCM440
2	Guide Plate	2	#500SP(CAC304+Gr)
3	Bushing	1	DU
4	Key	1	S45C
5	Control Bolt	1	SCM400
6	Fasten Nut	1	SCM400

※ Assembling Manual - page 66-67

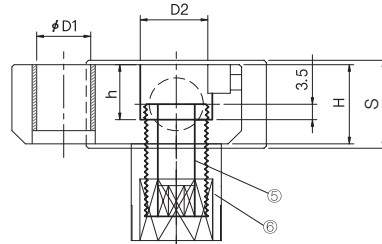
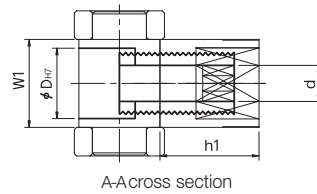
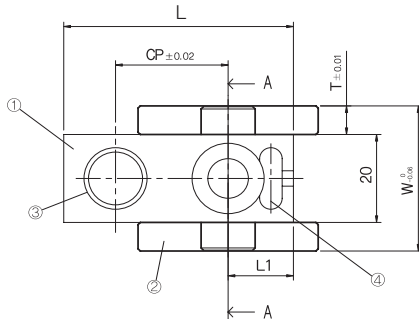

■ Fitting (Description)

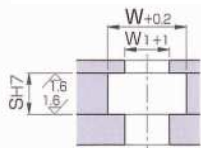

■ Guide Shaft BGPA BGPM

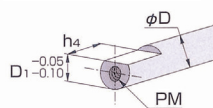

Order Catalog Code **D**

BDNL - 25

φ D	φ D1	D2	W	W1	T	L	L1	CP	S	H	h	φ d	h1	
12	10	11	30	17	6.5	43	12.5	20	-0.01	16	11.5	5.2	20	
16	12	15	33	20	6.5	51	14.5	25		18	12.5	8.2	22	
20	16	18	38	25	6.5	61	17	30		24	22	14.5	10.5	25
25	20	22	45	31	7	70	19	35	-0.03	26	16.5	12.5	28	
30	25	27.5	51	36	7.5	80	21.5	40		30	30	18.5	12.5	30
35	30	32.5	60	42	9	92	24	45		34	36	21.5	16.5	30
40	35	37.5	67	47	10	100	26.5	50	38	40	23.5	16.5	30	