

Catalog No.	Material	Hardness	GROUP
BTPV	SUJ2	55~60HRC	standard

Type	D	L	V	E	F	T	M	ℓ	N
BTPV L= 0.2-0.4	25	24	16	10	10	9	M8	16	M10
	30	29	20	13	13	11	M10	20	M12
	32	29	20	13	13	11	M10	20	M12
	35	34	24	16	16	13	M12	24	M14
	42	39	30	21	21	13	M12	24	M14

Order/ex Catalog no. - D - EA
BTPV - 42 - 20

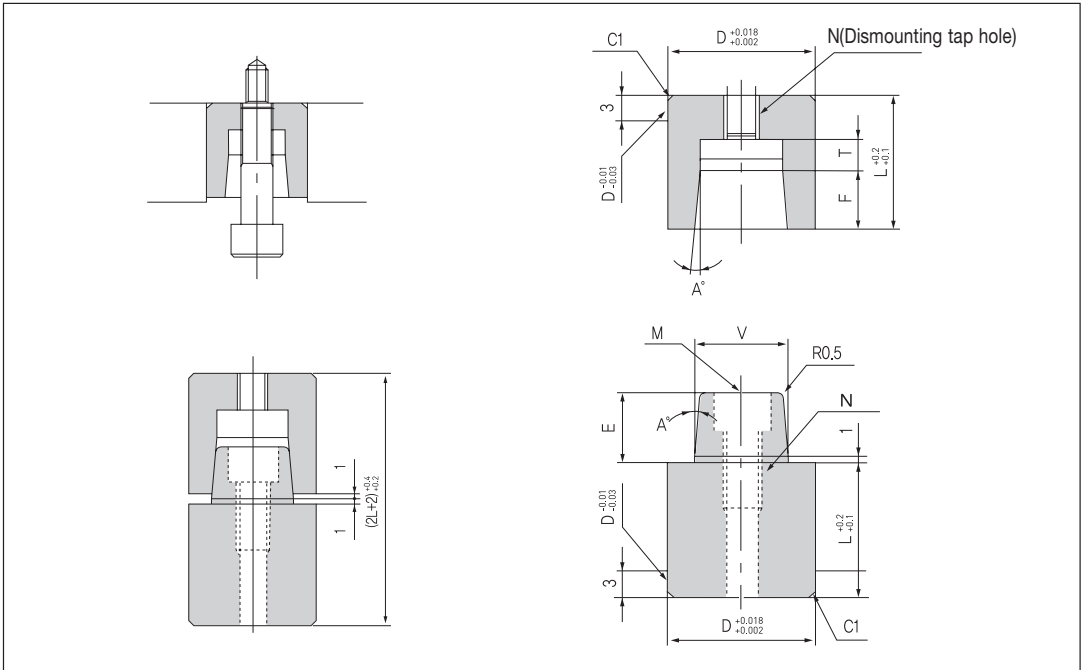
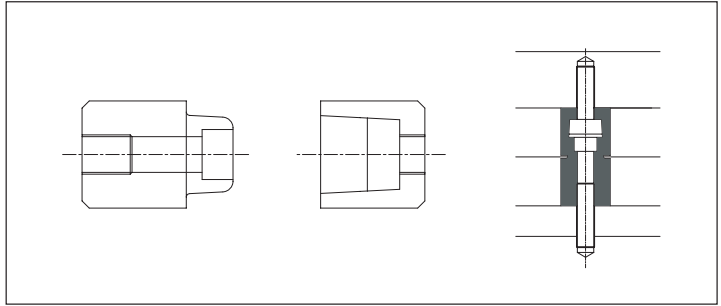

Catalog No.	Material	Hardness	GROUP
HTPV-B	SUJ2	55~60HRC	precision

Type	D	L	V	E	F	T	M	N
HTPV-B L = $\begin{matrix} 0 \\ 0.05 \end{matrix}$	30	29	22	13	13	9	M8	M10
	35	34	24	16	16	11	M10	M12
	42	39	30	21	21	13	M12	M14



Order/ex

Catalog no.

— D

HTPV-B — 42 — A°