

BNPS

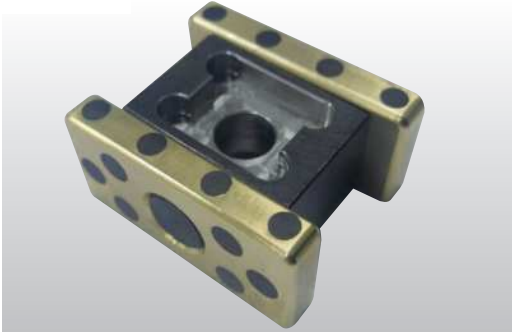

| No. | Description | Q'ty | Material |
|-----|------------------|------|-------------------|
| 1 | Core shaft Block | 1 | SCM440 |
| 2 | Guide Plate | 2 | #500SP(CAC304+Gr) |
| 2 | Guide Plate | 2 | SKD61 HRC 58 |

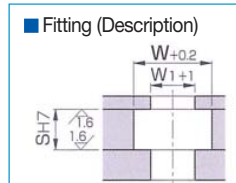
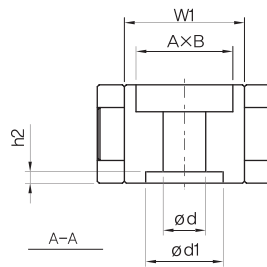
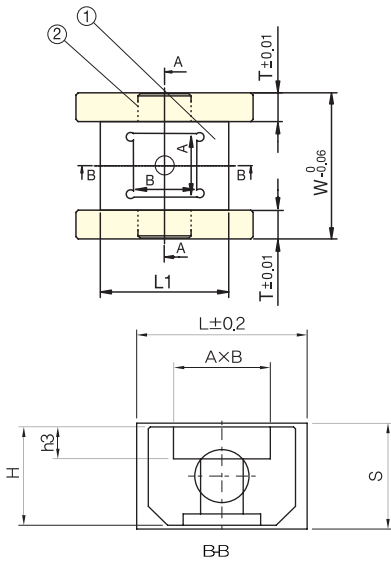

Order → Catalog Code $\square A \times B^{+0.05}_{+0.1}$ SKD 61

BNPS25 -25×12
 BNPS25 -20×22
 BNPS25 -25×12 - D
 BNPS25 -20×22 - D

| ø D | A × B | W | W1 | T | L | L1 | S | H | h2 | h3 | ø d | ø d1 | |
|-----|-------|----|----|-----|----|----|----|-------|----|-----|-----|------|----|
| 8 | 8×8 | 23 | 14 | 4.5 | 30 | 20 | 16 | -0.01 | 16 | - | 4 | 5.5 | - |
| 10 | 10×10 | 23 | 14 | 4.5 | 30 | 20 | 16 | | 16 | - | 4 | 5.5 | - |
| 12 | 12×12 | 30 | 17 | 6.5 | 35 | 25 | 20 | | 16 | - | 4 | 5.5 | - |
| 16 | 16×16 | 33 | 20 | 6.5 | 40 | 29 | 20 | | 18 | 3 | 5 | 9 | 16 |
| 20 | 20×20 | 38 | 25 | 6.5 | 40 | 34 | 24 | -0.03 | 22 | 5.5 | 5 | 11 | 20 |
| 25 | 25×25 | 45 | 31 | 7 | 45 | 38 | 26 | | 26 | 5.5 | 6 | 11 | 20 |
| 30 | 30×30 | 51 | 36 | 7.5 | 55 | 43 | 30 | | 30 | 3.5 | 6 | 11 | 20 |
| 35 | 35×35 | 60 | 42 | 9 | 70 | 48 | 34 | | 36 | 4 | 8 | 13 | 26 |
| 40 | 40×40 | 67 | 47 | 10 | 80 | 53 | 38 | 40 | 4 | 8 | 13 | 26 | |