

BBNS

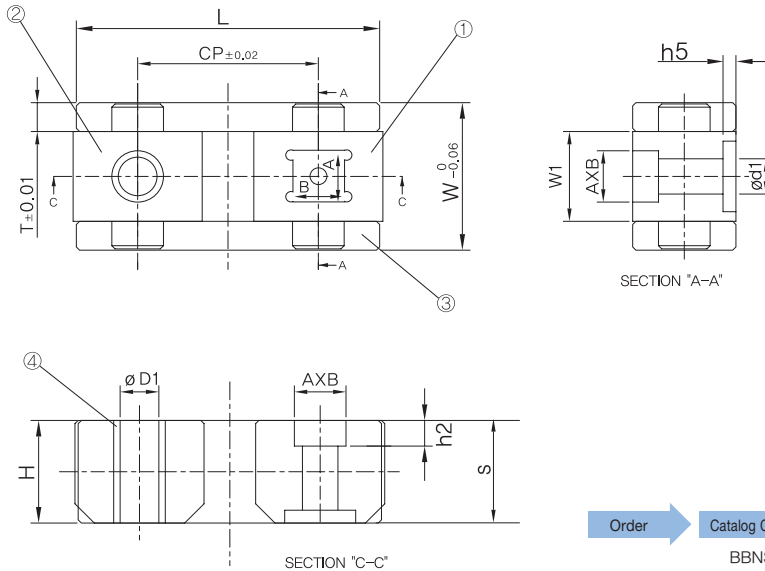

Patent No. : 10-0746267

No	Description	Q'ty	Material
1	Core shaft Block	1	SCM440
2	Guide Block	1	SCM440
3	Guide Plate	2	#500SP(CAC304+Gr)
4	Bushing	1	DU



BBNS

A×B	ø D1	W	W1	T	L	CP	H	S	h2	h5	ø d	ø d1
8×8	6	19	10	4.5	47	28	16	14	4	-	4.5	-
10×10	8	21	12	4.5	53	32	16	16	4	-	5.5	-
12×12	10	30	17	6.5	60	36	16	20	4	-	5.5	-
16×16	12	33	20	6.5	70	42	18	20	5	3	9	16
20×20	16	38	25	6.5	80	46	22	24	5	5.5	11	20
25×25	20	45	31	7	93	54	26	26	6	5.5	11	20