

# BNDW / BNDS BADW / BADS

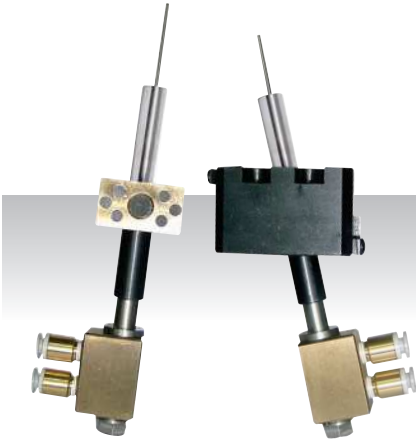

## WATER COOLING UNIT SET (Feature)

- Water Cooling Unit. Can be applied with a Diameter of Core Shaft 12-40.
- This Unit allows easy installation with Core Unit.

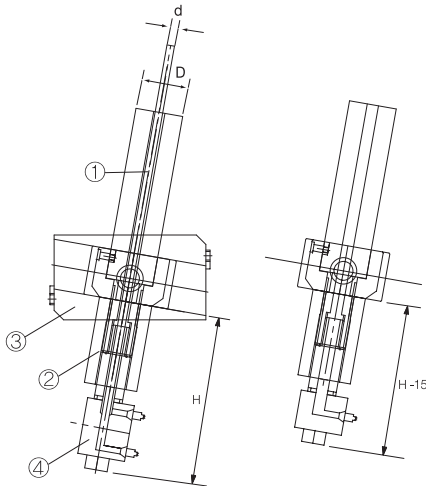

No.	Description	Q'ty	Material
1	Core Shaft	1	SUJ2
2	Core Shaft Fixed Nut	1	S45C
3	Core Unit	1	SUS
4	Water Cooling Unit	1	SUS, CAC304

### c) BASN, BNP

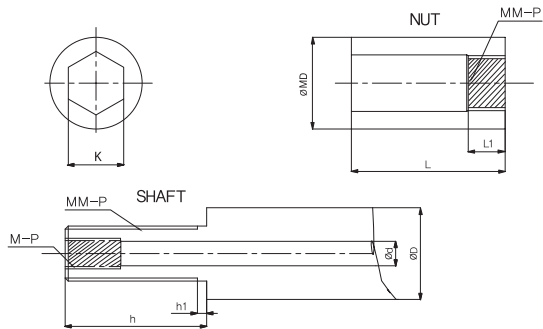

Warning- Don't press too much pressure on screw parts when assembling WTDW/ WTD to avoid any breakdown.

(M-P) Screw pitch position might be changed.

### Order

- BADW - D- $\phi$
- BADS - D- $\phi$
- BNDW - D
- BNDS - D
- NUT - D

Screw Shank(mm)	MAX Torque(Nm)
M6	7.5
M8	8.9
M12	26.6

	ØD	Ød	ØMD	M-P	MM-P	h	h1	L	L1	ØK	H	SHAFT
N U T / S H A F T	12	4	16	6-0,75	10-1,25	18	5	20	10	10	78	Indicate what length you required
	16	6	20	8-1,0	14-1,5	22	5	25	12	14	82	
	20	6	22		14-1,5	25	5	25	12	14	82	
	25	9	28	12-1,25	18-1,5	30	8	30	16	19	85	
	30	9	34		22-1,5	30	8	30	16	19	83	
	35	9	34		22-1,5	34	10	30	16	22	85	
	40	9	34		22-1,5	35	12	30	18	22	84	