

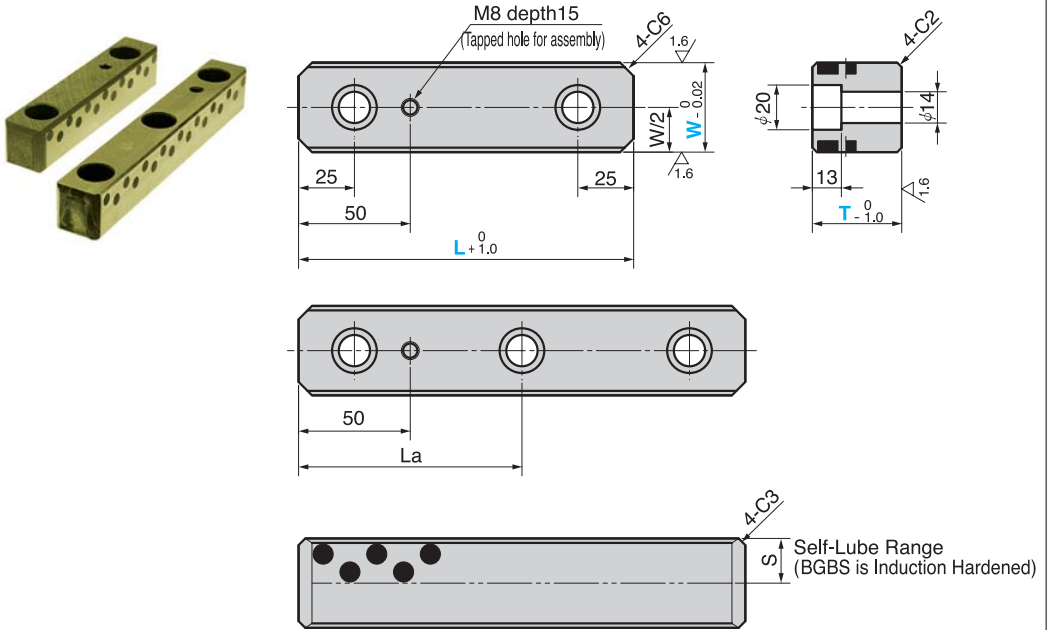

Guide Rail Center Kye Type – For Slide Core

- BGBFT** (FC with Graphite Type)
- BGBST** (Steel with Graphite Type)
- BGBWT** (Bronze with Graphite Type)



• W=60, L ≥ 250 Only

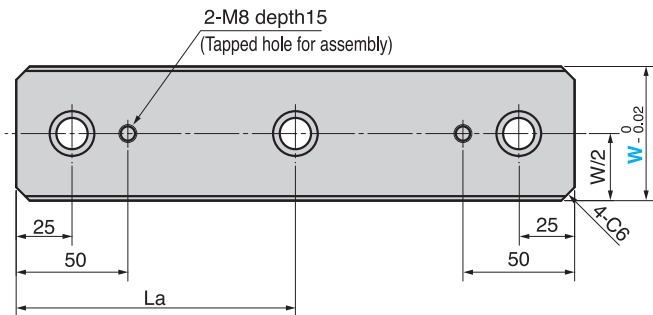

Material
 BGBFT FC250 (I 185-88E A A48-83) with Graphite
 BGBST S55C (I C55 A 1055) with Graphite
 HRC 40 to 45 (S Area)
 Induction Hardened
 BGBWT Bronze with Graphite

■ We are ready to accept requests or orders for special parts.



La	S	Catalog No.	W	L	T
-				100	
-				150	
100				200	
125			30	250	30
150				300	
175	15	BGBFT		350	
-		BGBST		100	
-				150	
100			40	200	30
125				250	
150				300	
175				350	
-				100	
-				150	
100	20	BGBFT	40	200	40
125		BGBST		250	
150		BGBWT		300	
175				350	
-				100	
125	25	BGBWT	60	250	40
150				300	
175				350	



Order

Catalog No.	W	-	L	-	T
BGBFT	30	-	150	-	30



Option

Option Code	Specification
CM	With chamfering (C17) on corners for relief (4 corners). Please instruct CM17 when ordering. This option is available only for W=40, 60 (without BGBS)

•CM Specification

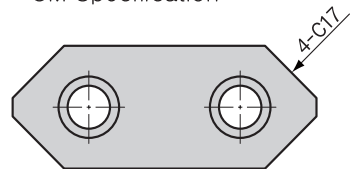

Order

BGBFT 30-150-30-CM17